

EU RO Mutual Recognition Technical Requirements

MECHANICAL JOINTS	Version	0.5
	Adoption Date	1 January 2023
	Application Date	1 July 2023
	Tier	1
This document is subject to controlled issue and can be found here: http://www.euromr.org/technical-requirements *** Uncontrolled if downloaded or printed ***		

1. PRODUCT DESCRIPTION	1
2. DESIGN EVALUATION	3
3. PRODUCTION REQUIREMENTS	12
4. MARKING REQUIREMENTS	12
5. TYPE APPROVAL CERTIFICATE CONTENT	13
6. APPROVAL DATE AND REVISION NUMBER	13
7. BACKGROUND INFORMATION / REFERENCES	14
8. MAINTENANCE / CLARIFICATION OF TECHNICAL REQUIREMENTS	14
9. LEGAL PROVISIONS / COPYRIGHT	14

1. PRODUCT DESCRIPTION

1.a General description of the product

- a) This Technical Requirement apply to mechanical joints, so called slip type or grip type or machine grooved type as shown in **Figure. 1** for both fire resistant and non-fire-resistant type;
- b) "**Mechanical joints**" means devices intended for direct connection of pipe lengths other than by welding, flanges or threaded joints.

EU RO Mutual Recognition Technical Requirements

MECHANICAL JOINTS	Version	0.5
	Adoption Date	1 January 2023
	Application Date	1 July 2023
	Tier	1
This document is subject to controlled issue and can be found here: http://www.euromr.org/technical-requirements *** Uncontrolled if downloaded or printed ***		

Figure 1

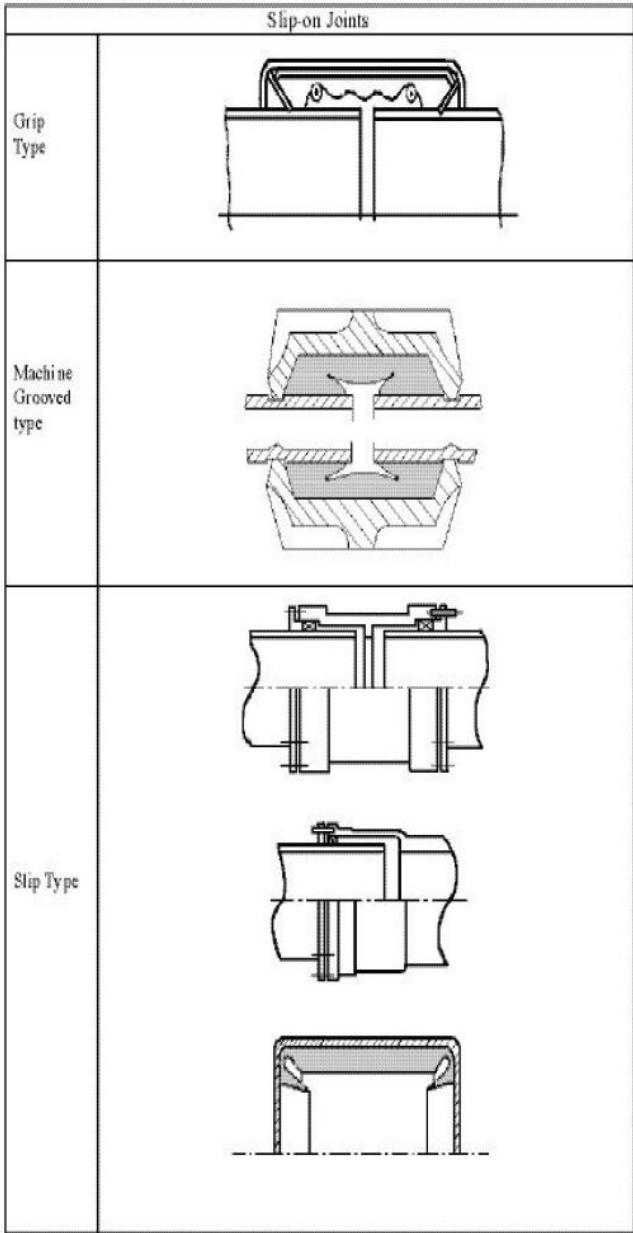

EU RO Mutual Recognition Technical Requirements

MECHANICAL JOINTS	Version	0.5
	Adoption Date	1 January 2023
	Application Date	1 July 2023
	Tier	1
This document is subject to controlled issue and can be found here: http://www.euomr.org/technical-requirements *** Uncontrolled if downloaded or printed ***		

1.b Application limitations†

- a) Application of mechanical joints, their acceptable use for each service, the dependence upon the class of piping system, pipe dimensions, working pressure and temperature are defined in the Classification Rules of individual EU ROs;
- b) Piping, in which a mechanical joint is fitted, shall be adequately adjusted, aligned and supported. Supports or hangers shall not be used to force alignment of piping at the point of connection;
- c) Typical application limitations are given by IACS UR P2 Rev.8 March 2016 in its tables 7 and 8 where classes of piping system are defined in its figure 1 and table 1.

† The EU MR type approved product is generally not used as a stand-alone product, but integrated as component in a sub-system or system. When a product is presented with an EU RO MR Type Approval Certificate for given application, its acceptability with regards to conditions defined in 1b, 1c and 1d of this Technical Requirement will be evaluated by the EU RO in charge of classing the ship or being in charge of the unit/system certification.

1.c Intended use

These Technical Requirements apply to mechanical joints intended for use in marine piping systems.

1.d System context

Application of the joint type for a given piping system of a given vessel is subject to the approval of the individual EU RO classing the vessel.

2. DESIGN EVALUATION

2.a Engineering evaluation requirements

2.a.i. Technical Requirements

- a) Due to the great variations in design and configuration of mechanical joints, no specific recommendation regarding calculation method for theoretical

EU RO Mutual Recognition Technical Requirements

MECHANICAL JOINTS	Version	0.5
	Adoption Date	1 January 2023
	Application Date	1 July 2023
	Tier	1
This document is subject to controlled issue and can be found here: http://www.euromr.org/technical-requirements *** Uncontrolled if downloaded or printed ***		

strength calculations is given in these Technical Requirements. The Type Approval is to be based on the results of testing of the actual joints;

- b) The materials used for mechanical joints shall be compatible with the piping material and internal and external media;
- c) The manufacturer shall submit evidence to substantiate that all components are adequately resistant to working the media at design pressure and temperature specified.

2.a.ii. Technical documents to be submitted

IMPORTANT: The English Language shall be used for all submitted documents.

Following documents and information are to be submitted by Manufacturer:

- a) Description of the product;
- b) Typical sectional drawings with all dimensions necessary for evaluation of joint design;
- c) Specification of materials used for all components of the assembly;

Along with documents showing:

- d) Maximum design pressures (pressure and vacuum);
- e) Maximum and minimum design temperatures;
- f) Conveyed media;
- g) Intended services;
- h) Maximum axial, lateral and angular deviation, allowed by manufacturer;
- i) Installation details;
- j) Marking details.

2.b Type testing requirements

2.b.1 Test program†

The testing program shall be submitted to the EU RO for approval. Tests required are indicated in **Table 2**. These tests are to be witnessed by the EU RO. In cases where the tests are conducted at Nationally Accredited Laboratories, the presence of the EU RO surveyor may be omitted.

EU RO Mutual Recognition Technical Requirements

MECHANICAL JOINTS	Version	0.5
	Adoption Date	1 January 2023
	Application Date	1 July 2023
	Tier	1
<p>This document is subject to controlled issue and can be found here: http://www.euromr.org/technical-requirements *** Uncontrolled if downloaded or printed ***</p>		

Table 2

Tests	Grip type & Machine grooved type	Slip type
Tightness test	+	+
Vibration (fatigue) test	+	-
Pressure pulsation test ¹	+	-
Burst pressure test	+	+
Pull-out test	+	-
Fire endurance test	+	+
Vacuum test	+	+
Repeated assembly test	+	-

Abbreviations:

+ Test is required

- Test is not required

NOTES:

1. for use in those systems where pressure pulsation other than water hammer is expected.

2.b.2 Selection of Test Specimen†

- a) Test specimens shall be selected from production line or at random from stock in the presence of an EU RO surveyor;
- b) Where approval is applied for a range of sizes of a given type of mechanical joints, at least three separate sizes representative of the range, from each type of joints shall be type tested;
- c) The selected specimens shall be verified for compliance with the technical documentation to the satisfaction of the attending EU RO surveyor.

† For further clarification of witnessing of tests and sampling the test specimen(s), refer to paragraphs 6, 7 and 8 of the EU RO "Design Evaluation Scheme" procedure (Appendix V of EU RO Framework Document for the Mutual Recognition of Type Approval found on <http://www.euromr.org/Guidance%20for%20Mutual%20Recognition>).

EU RO Mutual Recognition Technical Requirements

MECHANICAL JOINTS	Version	0.5
	Adoption Date	1 January 2023
	Application Date	1 July 2023
	Tier	1
This document is subject to controlled issue and can be found here: http://www.euomr.org/technical-requirements *** Uncontrolled if downloaded or printed ***		

2.b.3 Mechanical Joint Assembly

- a) Assembly of mechanical joints should consist of components selected in accordance with [2.b.4 ii] and the pipe sizes appropriate to the design of the joints;
- b) Where pipe material could affect the performance of mechanical joints, the selection of joints for testing shall take the pipe material into consideration;
- c) Where not specified, the length of pipes to be connected by means of the joint to be tested shall be at least five times the pipe diameter;
- d) In all cases, the assembly of the joint shall be carried out only in accordance the manufacturer's instructions;
- e) No adjustment operations on the joint assembly, other than that specified by the manufacturer, are permitted during the test.

2.b.4 Methods of tests

i. Test fluid

Unless otherwise specified, water or oil as test fluid is to be used.

ii. Tightness test

All mechanical joints are to be subjected to a tightness test, as follows;

- The mechanical joint assembly test specimen shall be connected to the pipe or tubing in accordance with the requirements of [2.b.4 iii] and the manufacturer's instructions, filled with test fluid and de-aerated;
- The pressure inside the joint assembly shall be slowly increased to 1.5 times the design pressure. This test pressure shall be retained for a minimum period of 5 minutes. In the event of a drop in pressure or visible leakage, the test (including fire test) is to be repeated for two further specimens. If, during the repeat test, one test piece fails the coupling is regarded as having failed.

iii. Vibration (fatigue) test for grip type and machine grooved type joints

- Mechanical joints assembly shall be subject to the vibration test detailed in a) to h) below. Conclusions of the vibration tests should show no leakage or damage

EU RO Mutual Recognition Technical Requirements

MECHANICAL JOINTS	Version	0.5
	Adoption Date	1 January 2023
	Application Date	1 July 2023
	Tier	1
This document is subject to controlled issue and can be found here: http://www.euromr.org/technical-requirements *** Uncontrolled if downloaded or printed ***		

- Grip type joints and other similar joints containing elastic elements shall be tested in accordance with the method detailed in **a) to h)** below. A test rig of cantilever type used for testing fatigue strength of components may be used. The test specimen being tested is to be arranged in the test rig as shown in **Figure 2**:

Figure 2

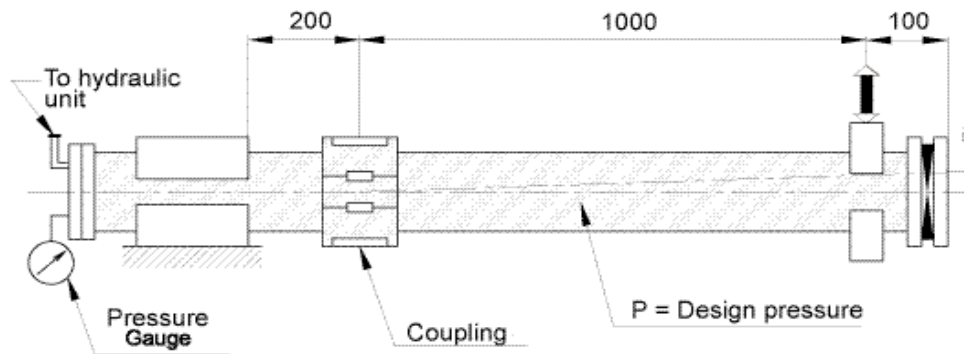

- Two lengths of pipes shall be connected by means of joint assembly specimen to be tested.
- One end of the pipe shall be rigidly fixed while the other end shall be fitted to the vibrating element on the rig. The length of pipe connected to the fixed end should be kept as short as possible and in no case exceed 200 mm.
- Mechanical joint assemblies shall not be longitudinally restrained.
- The assembly shall be filled with test fluid, de-aerated and pressurized to the design pressure of the joint. Preliminary angle of deflection of pipe axis shall be equal to the maximum angle of deflection, as recommended by the manufacturer.
- The amplitude shall be measured at 1m distance from the centre line of the joint assembly at free pipe end connected to the rotating element of the rig. (see **Figure 2**).
- Parameters of testing are to be as indicated below and to be carried out on the same assembly:

EU RO Mutual Recognition Technical Requirements

MECHANICAL JOINTS	Version	0.5
	Adoption Date	1 January 2023
	Application Date	1 July 2023
	Tier	1
<p>This document is subject to controlled issue and can be found here: http://www.euromr.org/technical-requirements *** Uncontrolled if downloaded or printed ***</p>		

Number of cycles	Amplitude, mm	Frequency, Hz
$3 \cdot 10^6$	± 0.06	100
$3 \cdot 10^6$	± 0.5	45
$3 \cdot 10^6$	± 1.5	10

- g) Pressure during the test shall be monitored. In the event of a drop in the pressure and visual signs of leakage the test is to be repeated as described in the Burst Pressure Test [see **2.b.4 v**];
- h) Visual examination of the joint assembly is to be carried out for signs of damage which may eventually cause leakage.
- iv. **Pressure pulsation test for grip type and machine grooved type joints**
- a) The mechanical joint test specimen for carrying out this test may be the same as that used in the tightness test above provided it passed that test;
- b) The mechanical joint test specimen shall be connected to a pressure source capable of generating pressure pulses of magnitude as shown in **Figure 3**;
- c) Impulse pressure is to be raised from 0 to 1.5 times the design pressure of the joint with a frequency equal to 30-100 cycles per minute. The number of cycles is not to be less than 5×10^5 ;
- d) The mechanical joint is to be examined visually for sign of leakage or damage during the test.

EU RO Mutual Recognition Technical Requirements

MECHANICAL JOINTS	Version	0.5
	Adoption Date	1 January 2023
	Application Date	1 July 2023
	Tier	1
<p>This document is subject to controlled issue and can be found here: http://www.euromr.org/technical-requirements *** Uncontrolled if downloaded or printed ***</p>		

Figure 3 - Impulse pressure diagram

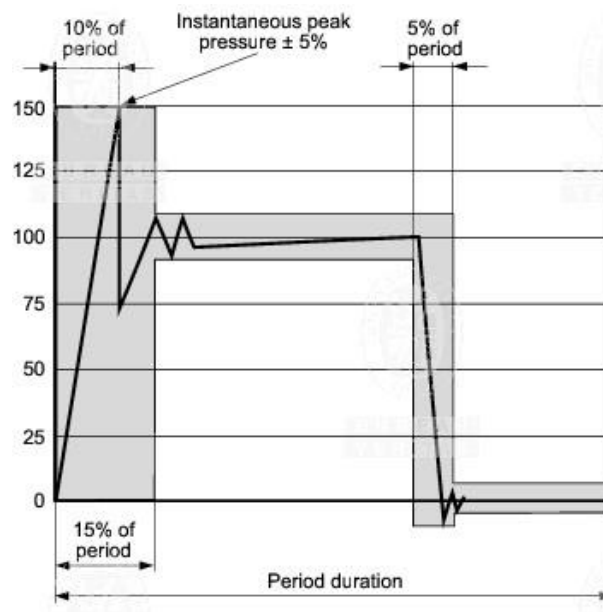

v. Burst pressure test

- a) Mechanical joints shall be tested where applicable, to a burst pressure of 4 times the design pressure. For design pressure above 200 bar the required burst pressure shall be agreed with the EU RO;
- b) Mechanical joint test specimen shall be connected to the pipe or tubing in accordance with the requirements of Pressure pulsation test, filled with test fluid, de-aerated and pressurized to test pressure with an increasing rate of 10% per minute of test pressure. The mechanical joint assembly intended for use in rigid connections of pipe lengths shall not be longitudinally restrained;
- c) Duration of this test shall not be less than 5 minutes at the maximum pressure.
- d) Where considered convenient, the same mechanical joint test specimen used in the tightness test may be used for the burst test, provided it passed the tightness test;

EU RO Mutual Recognition Technical Requirements

MECHANICAL JOINTS	Version	0.5
	Adoption Date	1 January 2023
	Application Date	1 July 2023
	Tier	1
This document is subject to controlled issue and can be found here: http://www.euromr.org/technical-requirements *** Uncontrolled if downloaded or printed ***		

e) The specimen may exhibit a small deformation whilst under test pressure, but no continuous movement on the pipe, leakage or visible cracks shall be permitted.

vi. Pull-out test for grip type and machine grooved type joints

- a) In order to determine the ability of a mechanical joint assembly to withstand the axial loading likely to be encountered in service without the connecting pipe becoming detached, the following pull-out test is to be carried out;
- b) Pipes of a suitable length shall be fitted to each end of the mechanical joint assembly test specimen. The test specimen is to be pressurized to its design pressure. When pressure is attained, an external axial load is to be imposed with a value calculated using the following formula:

$$L = \frac{\pi}{4} D^2 p$$

Where D =- Pipe outside diameter, mm

p =- Design pressure, N/mm²

L =- Applied axial load, N

- c) The pressure and axial load shall be maintained for a period of 5 minutes;
- d) During the test, the pressure is to be monitored and relative movement between the joint assembly and the pipe shall be measured;
- e) The mechanical joint assembly shall be visually examined for a drop in pressure and signs of leakage or damage. There shall be no movement between the mechanical joint assembly and the connecting pipes.

vii. Fire endurance test for fire resistant type

- a) The fire endurance test shall be conducted on the selected test specimens as per the following standards and clarifications:
- ISO 19921: 2005(E): Ships and marine technology – Fire resistance of metallic pipe components with resilient and elastomeric seals – Test methods;
 - ISO 19922: 2005(E): Ships and marine technology – Fire resistance of metallic pipe components with resilient and elastomeric seals –

EU RO Mutual Recognition Technical Requirements

MECHANICAL JOINTS	Version	0.5
	Adoption Date	1 January 2023
	Application Date	1 July 2023
	Tier	1
This document is subject to controlled issue and can be found here: http://www.euromr.org/technical-requirements *** Uncontrolled if downloaded or printed ***		

Requirements imposed on the test bench.

b) Clarifications to the standard requirements :

- If the fire test is conducted with circulating water at a pressure different from the design pressure of the joint (however of at least 5 bar) the subsequent pressure test shall be carried out to twice the design pressure;
- A selection of representative nominal bores may be tested in order to evaluate the fire resistance of a series or range of mechanical joints of the same design. The smallest and biggest size of the range shall, in all cases, be tested. For the sizes between the smallest and biggest, the testing of a mechanical joint with nominal bore (Dn) will qualify other mechanical joints up to 2xDn.
-
- Thermal insulation materials applied on couplings are to be non-combustible in dry condition and when subjected to oil spray. A non-combustibility test according to ISO 1182 is to be carried out.

viii. **Vacuum test**

- a) The mechanical joint assembly shall be connected to a vacuum pump and subjected to a pressure of 170 mbar absolute. Once this pressure is stabilized, the specimen under test shall be isolated from the vacuum pump and the pressure is to be maintained for a period of 5 minutes;
- b) No internal pressure rise is permitted.

ix. **Repeated assembly test for grip type and machine grooved type joints**

- a) The mechanical joint test specimens shall be dismantled and reassembled 10 times in accordance with manufacturer's instructions and then subjected to the tightness test.

2.b.5 Test Results Acceptance Criteria

- a) Where a mechanical joint assembly does not pass all or any part of the tests in **Table 2**, two assemblies of the same size and type that failed shall be tested and only those tests which the mechanical joint assembly failed in the first instance, are to be repeated;

EU RO Mutual Recognition Technical Requirements

MECHANICAL JOINTS	Version	0.5
	Adoption Date	1 January 2023
	Application Date	1 July 2023
	Tier	1
This document is subject to controlled issue and can be found here: http://www.euromr.org/technical-requirements *** Uncontrolled if downloaded or printed ***		

- b) In the event where one of the assemblies fails the second test, that size and type of assembly shall be considered unacceptable;
- c) The methods and results of each test shall be recorded and reproduced as and when required.

2.c Type testing requirement for certificate renewal

The manufacturer is to notify the RO of any modification or changes to the manufacturing specifications that may affect the MR TA to be renewed.

3. PRODUCTION REQUIREMENTS

Refer to EU RO "Product Quality Assurance (PQA)" procedure (Appendix VI of EU RO Framework Document for the Mutual Recognition of Type Approval).

4. MARKING REQUIREMENTS

Manufacturers of the approved equipment are, in principle, to mark the product before shipment for identification of approved equipment as per referenced standard. In addition, the following items to be marked at the suitable place:

- a) Manufacturer's name or logo;
- b) Type designation;
- c) Size;
- d) Maximum working pressure;
- e) Year/ serial number;
- f) Clamping torque of screws;
- g) Degree of fire resistance;
- h) Sealing material.

Where it is impracticable to affix the above marking due to the size of the product, the product shall be marked with at least:

- a) Manufacturer's name or logo;
- b) Type designation;
- c) Size;
- d) Maximum working pressure.

EU RO Mutual Recognition Technical Requirements

MECHANICAL JOINTS	Version	0.5
	Adoption Date	1 January 2023
	Application Date	1 July 2023
	Tier	1
<p>This document is subject to controlled issue and can be found here: http://www.euromr.org/technical-requirements *** Uncontrolled if downloaded or printed ***</p>		

5. TYPE APPROVAL CERTIFICATE CONTENT

The EU RO MR Type Approval Certificate shall contain the minimum information as defined in the EU RO Framework Document for the Mutual Recognition of Type Approval - see Appendix I EU RO MR Type Approval Certificate Information.

The following information is specifically applicable to products relevant to this technical requirement and shall be included on the relevant EU RO MR Type Approval Certificate:

- a) Reference of the Technical Requirement and testing standards applied;
- b) Material designation of major components, e.g., coupling housing, sealing etc.;
- c) Product type;
- d) Size range;
- e) Pressure and temperature range;
- f) Design drawing numbers;
- g) Test reports;
- h) Range of Application / Limitation;
- i) Production places;
- j) Marking of product.

6. APPROVAL DATE AND REVISION NUMBER

Date	Revision	Comment
8 July 2012	0.0	Accepted by Advisory Board
31 January 2014	0.1	Added reference to EU RO Framework Document for the Mutual Recognition of Type Approval.
31 January 2015	0.2	CRF018 – Revision to par. 2.a.ii - Technical documents to be submitted in English; CRF020 – Revision to par. 5 - 'Type Approval Certificate Content'.
1 April 2016	0.3	CRF025 – Updated to new MR TR document format incl. par. 8; CRF026/026a – Witness testing & control of test

EU RO Mutual Recognition Technical Requirements

MECHANICAL JOINTS	Version	0.5
	Adoption Date	1 January 2023
	Application Date	1 July 2023
	Tier	1
This document is subject to controlled issue and can be found here: http://www.euomr.org/technical-requirements *** Uncontrolled if downloaded or printed ***		

		specimen; CRF028 – addition of 6-month application clause.
1 January 2018	0.4	CRF029 - Update to align item 2.b.4.vi (Pull-out test for grip type and machine grooved type joints with IACS UR P2.11 Rev.4 March 2016; References to IACS UR P2 updated; Item 2.a.i (Technical Requirements) modified; Item 2.b.4.vii (Fire endurance test for fire resistant type) modified
1 January 2023	0.5	Added para 2.c Added para 9 Copyright (ref. 21030_)

7. BACKGROUND INFORMATION / REFERENCES

- a) IACS UR P2.7.4 (Rev. 8 March 2016) Mechanical joints;
- b) IACS UR P2.11 (Rev. 4 March 2016) type Approval of Mechanical Joints;
- c) ISO 19921:2005 (E);
- d) ISO 19922:2005 (E);
- e) EU RO Framework Document for the Mutual Recognition of Type Approval.

8. MAINTENANCE / CLARIFICATION OF TECHNICAL REQUIREMENTS

Anyone wishing to propose changes to this document or request clarification of technical issues should contact the EU RO MR Group Secretariat in the first instance: Secretariat@euomr.org.

Review and approval of change requests shall follow the EU RO MR Maintenance Process detailed in the EU RO Framework Document for the Mutual Recognition of Type Approval: <http://www.euomr.org/Guidance%20for%20Mutual%20Recognition>.

9. LEGAL PROVISIONS / COPYRIGHT

- a) Underlying legal provisions in accordance with EU RO Framework Document for

EU RO Mutual Recognition Technical Requirements

MECHANICAL JOINTS	Version	0.5
	Adoption Date	1 January 2023
	Application Date	1 July 2023
	Tier	1
This document is subject to controlled issue and can be found here: http://www.euomr.org/technical-requirements *** Uncontrolled if downloaded or printed ***		

the Mutual Recognition of Type Approval;

b) Copyright © 2022. All EU RO MR Group rights reserved. For a list of EU RO MR Group members please see <https://www.euomr.org/about-us>.

(The year is either the year of the inclusion of the copyright notice, 2022 for existing TRS, or the year of the adoption of any new TR.)

- END -

CONTROLLED DOCUMENT